

# PROSTAR™

SOLAR CONTROLLERS

---

## Installation, Operation and Maintenance Manual



**MORNINGSTAR**  
Corporation

[www.morningstarcorp.com](http://www.morningstarcorp.com)

### Models:

PS-15

PS-15M

PS-30

PS-30M

## SPECIFICATION SUMMARY

	PS-15	PS-30
Maximum Solar Input	60V	60V
Rated Solar Current	15A	30A
Rated Load Current	15A	30A
System Voltage	12/24V	12/24V
Digital Meter Option	Yes	Yes
Positive Ground Option	No	Yes

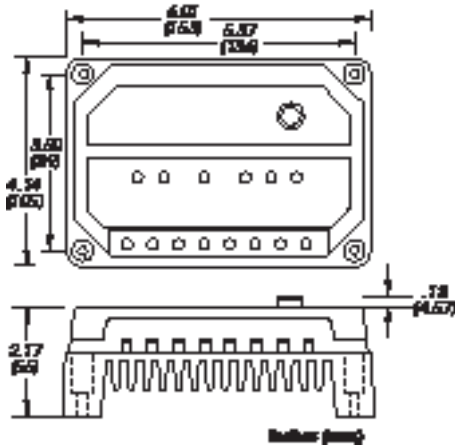

## CONTENTS

<b>1.0 IMPORTANT SAFETY INFORMATION</b> .....	5
<b>2.0 GENERAL INFORMATION</b> .....	16
<b>3.0 QUICK START INSTRUCTIONS</b> .....	17
<b>4.0 LED INDICATIONS</b> .....	19
<b>5.0 DIGITAL METER &amp; MANUAL DISCONNECT</b> .....	20
5.1 Digital Meter .....	20
5.2 Manual Disconnect.....	20
5.3 Display Disconnects & Protections.....	21
5.4 Self-Diagnostics (Self-Test).....	21
<b>6.0 INSTALLATION INSTRUCTIONS</b> .....	24
6.1 General Installation Notes.....	24
6.2 Installation Steps.....	26
<b>7.0 OPERATION</b> .....	31
7.1 Operator's Tasks.....	31
7.2 Operations and Functions.....	31
7.3 Protections.....	32
7.4 Inspection and Maintenance.....	34
7.5 Telecom Noise Jumper.....	35

## CONTENTS (Cont.)

---

<b>8.0 BATTERY CHARGING INFORMATION</b> .....	36
8.1 ProStar Charging Method .....	36
8.2 Select Battery Type.....	37
8.3 ProStar Charging Features.....	37
<b>9.0 TESTING and TROUBLESHOOTING</b> .....	39
9.1 Self-diagnostics.....	39
9.2 Technical Support.....	39
9.3 Testing with a Power Supply.....	39
9.4 Troubleshooting.....	40
<b>10.0 TECHNICAL SPECIFICATIONS</b> .....	45
<b>11.0 CERTIFICATIONS</b> .....	48

## 1.0 IMPORTANT SAFETY INFORMATION

### SAVE THESE INSTRUCTIONS.

This manual contains important safety, installation, operating and maintenance instructions for the ProStar PWM solar controller.

The following symbols are used throughout this manual to indicate potentially dangerous conditions or mark important safety instructions:



**WARNING:** *Indicates a potentially dangerous condition. Use extreme caution when performing this task.*

---



**CAUTION:** *Indicates a critical procedure for safe and proper operation of the controller.*

---



**NOTE:** *Indicates a procedure or function that is important to the safe and proper operation of the controller.*

---

### CONSIGNES IMPORTANTES DE SÉCURITÉ

#### CONSERVEZ CES INSTRUCTIONS:

Ce manuel contient des instructions importantes de sécurité, d'installations et d'utilisation du contrôleur solaire ProStar PWM.

Les symboles suivants sont utilisés dans ce manuel pour indiquer des conditions potentiellement dangereuses ou des consignes importantes de sécurité.



**AVERTISSEMENT:** Indique une condition potentiellement dangereuse. Faites preuve d'une prudence extrême lors de la réalisation de cette tâche.



**PRUDENCE:** Indique une procédure critique pour l'utilisation sûre et correcte du contrôleur.



**REMARQUE:** Indique une procédure ou fonction importante pour l'utilisation sûre et correcte du contrôleur.

#### Safety Information

- Read all of the instructions and cautions in the manual before beginning installation.
- There are no user serviceable parts inside the ProStar . Do not disassemble or attempt to repair the controller.



**WARNING: Risk Of Electrical Shock.**  
**NO POWER OR ACCESSORY TERMINALS ARE ELECTRICALLY ISOLATED FROM DC INPUT, AND MAY BE ENERGIZED WITH HAZARDOUS SOLAR VOLTAGE. UNDER CERTAIN FAULT CONDITIONS, BATTERY COULD BECOME OVER-CHARGED. TEST BETWEEN ALL TERMINALS AND GROUND BEFORE TOUCHING.**

- External solar and battery disconnects are required.
- Disconnect all sources of power to the controller before installing or adjusting the ProStar .
- There are no fuses or disconnects inside the ProStar. Do not attempt to repair.

#### Informations de Sécurité

- Lisez toutes les instructions et les avertissements figurant dans le manuel avant de commencer l'installation.
- Le ProStar ne contient aucune pièce réparable par l'utilisateur. Ne démontez pas ni ne tentez de réparer le contrôleur.



**AVERTISSEMENT: Risque De Choc Électrique.**  
**NON ALIMENTATION OU AUX BORNES D'ACCESSOIRES SONT ISOLÉS ÉLECTRIQUEMENT DE L'ENTRÉE DE C.C ET DOIT ÊTRE ALIMENTÉS À UNE TENSION DANGEREUSE SOLAIRE. SOUS CERTAINES CONDITIONS DE DÉFAILLANCE, LA BATTERIE POURRAIT DEVENIR TROP CHARGÉE. TEST ENTRE TOUTES LES BORNES ET LA MASSE AVANT DE TOUCHER.**

- External solaire et la batterie se déconnecte sont nécessaires.
- Déconnectez toutes les sources d'alimentation du contrôleur avant d'installer ou de régler le ProStar .
- Le TriStar MPPT ne contient aucun fusible ou interrupteur. Ne tentez pas de réparer.
- Installez des fusibles/coupe-circuits externes selon le besoin.

## Installation Safety Precautions

---



**WARNING:** *This unit is not provided with a GFDI device. This charge controller must be used with an external GFDI device as required by the Article 690 of the National Electrical Code for the installation location.*

- Mount the ProStar indoors. Prevent exposure to the elements and do not allow water to enter the controller.
- Install the ProStar PWM in a location that prevents casual contact. The ProStar PWM heatsink can become very hot during operation.
- Use insulated tools when working with batteries.
- Avoid wearing jewelry during installation.
- The battery bank must be comprised of batteries of same type, make, and age.
- UL/IEC 62109 certified for use in negative ground or floating systems only
- Do not smoke near the battery bank.
- Power connections must remain tight to avoid excessive heating from a loose connection.
- Use properly sized conductors and circuit interrupters.

- The grounding terminal is located in the wiring compartment and is identified by the symbol below:

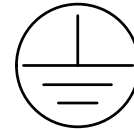

Ground Symbol

This charge controller is to be connected to DC circuits only. These DC connections are identified by the symbol below:



Direct Current Symbol

The ProStar PWM controller must be installed by a qualified technician in accordance with the electrical regulations of the country where the product is installed.

A means of disconnecting all power supply poles must be provided. These disconnects must be incorporated in the fixed wiring.

The Prostar PWM negative power terminals are common, and must be grounded as instructions, local codes, and regulations require.

## Précautions de Sécurité D'installation

---



**AVERTISSEMENT:** L'appareil n'est pas fourni avec un dispositif GFDI. Ce contrôleur de charge doit être utilisé avec un dispositif GFDI externe tel que requis par l'Article 690 du Code électrique national de l'emplacement de l'installation.

- Montez le ProStar à l'intérieur. Empêchez l'exposition aux éléments et la pénétration d'eau dans le contrôleur.
- Installez le PS-PWM dans un endroit qui empêche le contact occasionnel. Le dissipateur de chaleur ProStar PWM peut devenir très chaud pendant le fonctionnement.
- Utilisez des outils isolés pour travailler avec les batteries.
- Évitez le port de bijoux pendant l'installation.
- Le groupe de batteries doit être constitué de batteries du même type, fabricant et âge.
- UL/IEC 62109 certifié pour utilisation au négatif à la masse ou les systèmes flottants seulement.
- Ne fumez pas à proximité du groupe de batteries.
- Les connexions d'alimentation doivent rester serrées pour éviter une surchauffe excessive d'une connexion desserrée.
- Utilisez des conducteurs et des coupe-circuits de dimensions adaptées.

- La borne de mise à la terre se trouve dans le compartiment de câblage et est identifiée par le symbole ci-dessous estampillé dans le boî:

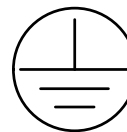

- Ce contrôleur de charge ne doit être connecté qu'à des circuits en courant continu. Ces connexions CC sont identifiées par le symbole ci-dessous:



Le contrôleur ProStar PWM doit être installé par un technicien qualifié conformément aux réglementations électriques du pays où est installé le produit.

Un moyen d'assurer la déconnexion de tous les pôles de l'alimentation doit être fourni. Cette déconnexion doit être incorporée dans le câblage fixe.

Les bornes de puissance négative ProStar PWM sont communs et doivent être mise à la terre comme instructions, aux codes et règlements, exigent.

La fixation de la mise à la terre doit être fixée contre tout desserrage accidentel. Les ouvertures d'entrée au compartiment de câblage du ProStar PWM doivent être protégées avec conduit ou anneaux.

## Battery Safety

---



**WARNING:** A battery can present a risk of electrical shock or burn from large amounts of short-circuit current, fire, or explosion from vented gases. Observe proper precautions.



**AVERTISSEMENT:** Une batterie peut présenter a risque de choc électrique ou de brûlure de grandes quantités de court-circuit curlouer, incendie ou explosion de ventilé gaz. Observer précautions appropriées.



**WARNING:** Risk of Explosion. Proper disposal of batteries is required. Do not dispose of batteries in fire. Refer to local regulations or codes for requirements.



**AVERTISSEMENT:** Risque d'Explosion. Au rebut des piles est nécessaire. Ne pas jeter les piles dans le feu. Se référer aux réglementations locales ou des codes pour les exigences.



**CAUTION:** When replacing batteries, use properly specified number, sizes, types, and ratings based on application and system design.



**PRUDENCE:** Lorsque le remplacement des piles, utilisez correctement nombre spécifié, tailles, types et les évaluations basées sur conception de système et d'application.



**CAUTION:** Do not open or mutilate batteries. Released electrolyte is harmful to skin, and may be toxic.



**PRUDENCE:** Ne pas ouvrir ou mutiler les piles. L'électrolyte est nocif pour la peau et peut être toxique.

- Servicing of batteries should be performed, or supervised, by personnel knowledgeable about batteries, and the proper safety precautions.
- Be very careful when working with large lead-acid batteries. Wear eye protection and have fresh water available in case there is contact with the battery acid.
- Remove watches, rings, jewelry and other metal objects before working with batteries.
- Wear rubber gloves and boots
- Use tools with insulated handles and avoid placing tools or metal objects on top of batteries.
- Disconnect charging source prior to connecting or dis-connecting battery terminals.
- Determine if battery is inadvertently grounded. If so, remove the source of contact with ground. Contact with any part of a grounded battery can result in electrical shock. The likelihood of such a shock can be reduced if battery grounds are removed during installation and maintenance (applicable to equipment and remote battery supplies not having a grounded supply circuit).
- Carefully read the battery manufacturer's instructions before installing / connecting to, or removing batteries from, the ProStar PWM.

- Be very careful not to short circuit the cables connected to the battery.
- Have someone nearby to assist in case of an accident.
- Explosive battery gases can be present during charging. Be certain there is enough ventilation to release the gases.
- Never smoke in the battery area.
- If battery acid comes into contact with the skin, wash with soap and water. If the acid contacts the eye, flood with fresh water and get medical attention.
- Be sure the battery electrolyte level is correct before starting charging. Do not attempt to charge a frozen battery.
- Recycle the battery when it is replaced.
- Entretien des batteries devrait être effectué ou supervisé, par un personnel bien informé sur les piles et les précautions de sécurité appropriées.
- Soyez très prudent quand vous travaillez avec des grandes batteries au plomb. Portez des lunettes de protection et ayez de l'eau fraîche à disposition en cas de contact avec l'électrolyte.
- Enlevez les montres, bagues, bijoux et autres objets métalliques avant de travailler avec des piles.
- Porter des bottes et des gants de caoutchouc
- Utiliser des outils avec poignées isolantes et évitez de placer des outils ou des objets métalliques sur le dessus de batteries.
- Débrancher la source de charge avant de brancher ou dis-reliant les bornes de la batterie.
- Utilisez des outils isolés et évitez de placer des objets métalliques dans la zone de travail.
- Déterminer si batterie repose par inadvertance. Dans l'affirmative, supprimer la source du contact avec le sol. Contact avec n'importe quelle partie d'une batterie mise à la terre peut entraîner un choc électrique. La probabilité d'un tel choc peut être réduite si des motifs de batterie sont supprimés pendant l'installation et maintenance (applicable à l'équipement et les fournitures de pile de la télécommande n'ayant pas un circuit d'alimentation mise à la terre).
- Lisez attentivement les instructions du fabricant de la batterie avant d'installer / connexion à ou retrait des batteries du ProStar PWM.
- Veillez à ne pas court-circuiter les câbles connectés à la batterie.
- Ayez une personne à proximité qui puisse aider en cas d'accident.
- Des gaz explosifs de batterie peuvent être présents pendant la charge. Assurez-vous qu'une ventilation suffisante évacue les gaz.
- Ne fumez jamais dans la zone des batteries
- En cas de contact de l'électrolyte avec la peau, lavez avec du savon et de l'eau. En cas de contact de l'électrolyte avec les yeux, rincez abondamment avec de l'eau fraîche et consultez un médecin.
- Assurez-vous que le niveau d'électrolyte de la batterie est correct avant de commencer la charge. Ne tentez pas de charger une batterie gelée.
- Recyclez la batterie quand elle est remplacée.



## 2.0 GENERAL INFORMATION

Thank you for selecting the ProStar solar controller. This second generation ProStar adds new features and protections using highly advanced technology. Morningstar's patented PWM battery charging algorithm has also been further optimized for longer battery life and improved system performance.

Many functions of the ProStar are unique. Although the ProStar is very simple to use, please take the time to read this operator's manual and become familiar with the controller. This will help you to make full use of the many advantages the ProStar can provide for your solar system.

## 3.0 QUICK START INSTRUCTIONS

This section provides a brief overview of how to get started using the ProStar controller. However, please review the entire manual to ensure best performance and years of trouble-free service.



### **CAUTION: Equipment Damage**

*Do not wire any AC inverter to the load terminals of the ProStar. Damage to the load control circuit may result. An inverter should be wired to the battery. If there is a possibility that any other load will sometimes exceed the Prostar's maximum voltage or current limits, the device should be wired directly to the battery or battery bank. If load control is required, contact Morningstar Tech Support for assistance.*



### **PRUDENCE : Dommages matériels**

*Ne pas raccorder n'importe quel convertisseur aux bornes de la ProStar. Pourrait endommager le circuit de commande de charge. S'il y a une possibilité que n'importe quelle autre charge dépassera parfois la tension maximale de la Prostar ou limites de courant, l'appareil doit être câblé directement sur la batterie ou la batterie. Si le régulateur de charge est nécessaire, contacter le Support technique de Morningstar d'assistance*

1. Verify that the nominal array voltage matches the nominal battery voltage.
2. Verify that the solar and load currents will not exceed the ratings of the ProStar version being installed.
3. Verify that the solar input voltage (temperature compensated Voc) will not exceed the rating for the applicable system voltage
4. Mount the ProStar to a vertical surface. Allow space above and below the controller for air flow. The heat sink MUST be in a vertical (up & down) position.
3. Connect the Battery first. Observe that the Battery Status LEDs blink in sequence one time. Torque all the ProStar terminals tightly, but do not exceed 35 in-inb.
4. Connect the Battery Sense. This is recommended, but not required, if the battery is located more than 5 meters from the controller.

5. Connect the Solar. With sunlight, the green Charging LED will light.

6. Load terminals are provided to connect lights, DC appliances and other devices directly to the controller. Connect the Load. If there is a fault, the LEDs will begin blinking. Refer to section 4.0 of this manual to identify the fault.

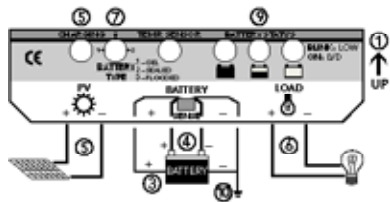

Rev: April 2001

7. Select the proper charging for the battery being used. Turn the rotary switch with a screwdriver to the Battery Type printed on the label. The Battery Status LEDs will blink 1, 2 or 3 times depending on the Battery Type selected.
8. For 12 or 24 Volt systems, the ProStar will automatically select the system voltage. If the system is 24 Volts, first confirm that the battery is above 15.5 Volts. The controller selects 12 or 24 Volts at start-up.
9. Observe the LEDs and digital meter (if provided) to confirm normal operation.
10. It is recommended that the system be properly grounded.

## 4.0 LED INDICATIONS

The four LEDs in the lower label indicate system status and various faults. These functions are described below.

### CHARGING (LED 1 – green)

ON: Battery charging during sunlight (always on during sunlight)

OFF: Normal during night (off during sunlight indicates solar reverse polarity or overcurrent)

### BATTERY STATUS (LEDs 2 – 4)

GREEN: ON indicates battery is near full charge BLINKING indicates PWM charging (regulation)

YELLOW: ON indicates battery at middle capacity

RED: BLINKING indicates a low charge state and low voltage disconnect (LVD) warning ; SOLID indicates that the load has been disconnected (LVD)

### FAULT INDICATIONS

G = green

Y = yellow

R = red

G/Y/R blinking together = battery select fault

R – Y sequencing = high temperature disconnect

R – G sequencing = high voltage disconnect

R/G – Y sequencing = load short circuit or overload

## 5.0 DIGITAL METER and MANUAL DISCONNECT

A digital meter is available with the ProStar controller as an option. If your version includes the meter display, this section will describe the information that can be displayed with the meter, and the added capabilities that are enabled by the push-button switch.

### 5.1 DIGITAL METER

A precision 3-digit digital meter will continuously display battery voltage, solar current, and the load current. The meter automatically scrolls through these 3 displays. The 3 red LEDs will indicate which parameter is being displayed.

The digital meter will operate from  $-30^{\circ}\text{C}$  to  $+85^{\circ}\text{C}$ . The values displayed are calibrated electronically in production and are accurate to within a few percent. Please note, however, that if the Battery Sense is not connected, the voltage displayed will be in error by the voltage drops in the battery wires.

### 5.2 MANUAL DISCONNECT

The push-button next to the digital display can disconnect the Load or both Load and Solar.

A second push of the button will return the controller back to normal operation.

**LOAD OFF:** A brief push of the button (less than 2 seconds) will disconnect the Load. The Solar remains on and charging.

**LOAD AND SOLAR OFF:** If the button is held down for 2 seconds, the Solar will also be disconnected.

When the button is pushed, the red LED inside the cap will light. In addition, the Load or both Load and Solar will display "OFF" in the digital meter to indicate the disconnected state.

### 5.3 DISPLAY DISCONNECTS & PROTECTIONS

The following protection functions and disconnect conditions will be displayed in the digital meter when they occur:

LVD – Low Voltage load Disconnect (load only)

HVD - High Voltage Disconnect (both solar and load).

Hot - High Temperature Disconnect (both solar and load)

OCP - Overcurrent and short circuit protection (load, solar over-current) short circuit protection (solar only)

0.0 - Short circuit protection (solar only)

### 5.4 SELF-DIAGNOSTICS (Self-test)

If the push-button is held down for 4 seconds, the ProStar will go into automatic self-diagnostics.

Note that the button must be released to start the self-test.

**NOTE:** The push-button can be used to toggle through the displays faster. The entire self-test takes 30 to 45 seconds. The load will be turned on for 0.1 second and may flash during the test. A short or overload condition could cause a controller re-start.

The following displays will occur (examples are used):

8.8.8 Self-test started, checking the digital meter segments  
12u The system voltage (12/24/48)  
15A ProStar current rating  
r 1.5 Software version installed  
E04 A fault has been detected (see list below)  
--- Display if no fault is found  
25c Temperature measured at the controller  
rP Remote temp probe is detected (if connected)  
25c Temperature at the remote probe (if connected)  
SEn Battery sense detected (if connected)  
S-1 Battery select position (1, 2, or 3)  
J-1 Telecom noise jumper cut (change to on-off regulation)  
End End of the self-test  
End---End *Display continue if no error was detected.*  
End End *Display continues if an error has been detected.*

To terminate the self-test, push the button. The self-test can be repeated to confirm the result.

Error list:

E01 Rotary switch battery selection failure  
E03 Voltage reference test failed (circuit, malfunctions)  
E04 Solar array current fault (circuit, FETs)  
E07 Load FETs off test (load connection, FETs shorted)  
E08 Load current fault (circuit, FETs)  
E09 Load FETs on test (load circuit, FETs open)  
E10 Internal temp sensor out of range high  
E11 Internal temp sensor out of range low  
E12 Remote temp probe out of range  
E13 Battery sense fault (battery V drop over 5V, no Sense negative connection)

**NOTE:** In addition to the self-test, observe the solar and load currents displayed in the meter. The self-diagnostics plus the currents displayed in the meter will provide a comprehensive test of the ProStar. Some faults may not be detected by the self-test, but the large majority of potential faults will be tested and reported in this self-diagnostic test.

Refer to section 9.0 for more information.

## 6.0 INSTALLATION INSTRUCTIONS

The ProStar is installed in 10 steps. Follow the procedure in section 6.2 for a proper installation and best performance.

### 6.1 GENERAL INSTALLATION NOTES

- The ProStar uses stainless steel fasteners, an anodized heat sink, and conformal coating to protect from harsh conditions. However, for acceptable service life extreme temperatures and marine environments should be avoided.
- The ProStar prevents reverse current leakage at night, so a blocking diode is not required in the system.
- The ProStar is designed to regulate ONLY solar (photovoltaic) power. Do not connect it to any other type of power generator. Do not attempt to regulate a wind turbine. However, other power sources can be connected directly to the battery.
- The connector terminals will accept a maximum wire size of AWG #6 / 16 mm<sup>2</sup> (solid/multistrand) or AWG #8 / 10 mm<sup>2</sup> (fine strand). Use a flathead insulated screwdriver, and torque tightly up to 35 in-lb.
- Stranded wires to be connected to the ProStar terminals should be prepared first with e.g. clamped copper heads, etc. to avoid the possibility of one conductor free out of the connection screw, and possible contact with the metal enclosure.
- Solar and Battery fuses or DC disconnects are not part of the ProStar controller.



**WARNING:** Solar and battery fuses or DC breakers are required in the system. These protection devices are external to the Prostar PWM controller, and must be a maximum of 18 amps for the PS-PWM-15/M and 37.5 amps for the PS-PWM-30/M.



**AVERTISSEMENT:** Solaire et batterie fusibles ou disjoncteurs DC sont nécessaires dans le système. Ces dispositifs de protection sont externes au contrôleur PS-PWM et doivent être un maximum de 18 ampères pour le PS-PWM-25/M et 37.5 ampères pour le PS-PWM-40/M.



**WARNING:** Installation must comply with all NEC requirements. All breakers must be properly rated for wire ampacity, which may require less than the maximum breaker sizes referenced above.



**AVERTISSEMENT:** Installation doit être conforme à toutes les requirements NEC. Tous les disjoncteurs doivent être correctement classifiés pour fil courant admissible, susceptible d'exiger moins que les tailles maximales disjoncteur référencés ci-dessus.



**WARNING:** Minimum over-current protection device interrupt ratings must be 2000A for 12V systems, and 4000A for 24V systems.



**AVERTISSEMENT:** Protection contre les surintensités minimum cotes d'interruption de périphérique doivent être de 2000 a 12V systèmes et 4000 a pour les systèmes de 24V.

**NOTE:** Carefully observe the LEDs at each connection. The LEDs will indicate proper polarity and a good connection.

## 6.2 INSTALLATION STEPS

Refer to the wiring connection diagram in section 3.0.

### STEP 1: Mounting

Inspect the controller for shipping damage. Mount the ProStar to a vertical surface (4 stainless steel #8 self-tapping screws are included). Tighten the mounting screws using care not to crack the plastic case. Do not install directly over an easily combustible surface since the heat sink may get hot under certain operating conditions.

**NOTE:** Heat sink must be in a vertical position (fins up and down).

Allow at least 15 cm (6 inches) space above and below the controller for air flow. Install in an area protected from direct rain and direct sun. If the controller is installed in an enclosure, some ventilation is recommended. Do not locate in an enclosure where battery gases can accumulate.

### STEP 2: Ratings

Confirm that the solar array and loads will not exceed the current rating of the ProStar version being installed.

Multiple ProStar units can be paralleled at the system battery to increase the solar capacity, but do not parallel loads.

Multiple ProStar units can be paralleled at the system battery to increase the solar capacity, but do not parallel loads.

Multiple ProStar units can be paralleled at the system battery to increase the solar capacity, but do not parallel loads.

**NOTE:** The battery should be connected first. This will activate the controller protection features, and will power the LEDs to guide installation and start-up.

### STEP 3: Battery Connection

Before connecting the battery, measure the battery's open-circuit voltage. It must be over 8 Volts to operate the controller. For 24 volt systems, the battery must be over 15.5 Volts or the ProStar will regulate for 12V. The 12/24V auto selection is only done at start-up.

Connect the battery and confirm that the 3 Battery Status LEDs blink in sequence. If they do not light, check the battery polarity (+/-) and battery voltage.



**CAUTION:** *The ProStar is protected against all faults EXCEPT a reversed battery connection together with a polarized or short circuited load. CONFIRM that the battery + and - wires are correctly connected before proceeding. Check the wires and the LEDs.*



**PRUDENCE:** *Le ProStar est protégé contre al défauts SAUF un inversé connexion de la batterie avec une charge de court-circuit courte ou polarisée. CONFIRMER que le batterie + et - fils sont connecté correctement avant de continuer. Vérifiez les câbles et les del.*

The green, yellow or red LED will light depending on the battery charge state. Confirm one of these LEDs is on before going to the next step.

## STEP 4: Battery Sense Cables

Battery sense connections are recommended if the controller is more than 5 meters from the battery. The Sense Wires, when connected directly to the battery, will improve the battery charging and control.

Both Sense wires (+/-) must be connected. A small wire size (18 AWG or larger) can be used for the Sense because the current is very low. Note that the middle 2 terminals are for sense (with the smaller wire slots in the case).

**NOTE:** If the Battery input voltage is more than 5 Volts different than the Sense due to voltage drops or faulty connections, the Sense input will not be recognized by the ProStar.

## STEP 5: Solar Connection

These terminals are used to connect the Solar (PV) array. First confirm that the solar modules are wired for the same voltage as the battery.

Use caution, since the solar array will produce power whenever in sunlight. If the solar is connected while in sunlight, the Charging LED indicator will light. Confirm proper connection with the Charging LED.

## STEP 6: Load Connection



### **CAUTION: Equipment Damage**

*Do not wire any AC inverter to the load terminals of the ProStar. Damage to the load control circuit may result. An inverter should be wired to the battery. If there is a possibility that any other load will sometimes exceed the Prostar's maximum voltage or current limits, the device should be wired directly to the battery or battery bank. If load control is required, contact Morningstar Tech Support for assistance.*



### **PRUDENCE : Dommages matériels**

*Ne pas raccorder n'importe quel convertisseur aux bornes de la ProStar. Pourrait endommager le circuit de commande de charge. S'il y a une possibilité que n'importe quelle autre charge dépassera parfois la tension maximale de la Prostar ou limites de courant, l'appareil doit être câblé directement sur la batterie ou la batterie. Si le régulateur de charge est nécessaire, contacter le Support technique de Morningstar d'assistance.*

Load terminals are provided to connect lights, DC appliances and other devices directly to the controller. Turn the load off, and connect the load wires to the Load terminals. Turn the load on to confirm a proper connection. If the load does not turn on, it could be for various reasons:

- the ProStar is in LVD (red LED on)
- there is a short circuit in the load (LEDs blinking R/G – Y)
- there is an overload condition (LEDs blinking R/G – Y)
- the load is not connected, not working, or turned off

Confirm the load is working properly before going to Step 7.

## STEP 7: Battery Type Selection

Using a small screwdriver, turn the rotary switch to select the Battery Type. There are 3 choices (see section 8.2):

1 = Gel battery

2 = Sealed battery

3 = Flooded battery

A proper selection will flash the 3 Status LEDs together: 1 time for Gel, 2 times for Sealed, and 3 times for Flooded.

If the rotary switch does not make a good contact with one of the three selections, the three LEDs will start flashing together and continue until a good contact is made.

#### **STEP 8: Confirm Installation**

After the connections are completed, observe the LEDs to make sure the controller is operating normally for system conditions. If the optional digital meter is provided, observe that the display is scrolling with proper voltage and amperage values. A self-test can be performed with the digital meter (see section 5.4).

#### **STEP 9: Grounding**

For safety and effective lightning protection, the negative conductor of the solar system should be properly grounded (see the NOTE below). In addition, the heat sink can be grounded with a #8-32 UNC or M4 screw (0.136 hole provided).

The Solar, Battery, and Load negative terminals are all connected together inside the ProStar per UL recommendations. No switching or measurement is done in the negative current path.

**NOTE:** For positive ground versions, the Solar, Battery and Load POSITIVE terminals are connected together inside the ProStar. The positive system conductor must be properly grounded. Make sure the upper label of the ProStar indicates "Positive Ground" above the version number to confirm this is a positive ground ProStar controller.

## **7.0 OPERATION**

### **7.1 OPERATOR'S TASKS**

The ProStar is a fully automatic solar system controller that includes many electronic functions to protect both the controller and the solar system. Battery charging is also fully automated (see section 8.0).

The only manual tasks performed by the operator are:

- a. Installation (see section 6.2)
- b. Battery type selection (see section 6.2, Step 7)
- c. Disconnect button / Self-test (see section 5.2 and 5.4)
- d. Reset if a load short circuit does not automatically clear (see section 7.3)
- e. Maintenance (see section 7.4)

### **7.2 OPERATIONS & FUNCTIONS**

The solar system operator should become familiar with the following operating functions of the ProStar controller. Refer to the Technical Specifications (section 10.0) for actual setpoints and other parameter values.

- 100% Solid State: All power switching is done with FETs. No mechanical relays are used in the controller.
- Battery Charge Regulation: The ProStar is a PWM battery charger. See the next section (8.0) for a description of battery charging.
- Low Voltage Load Disconnect (LVD): An automatic load disconnect protects the battery from deep discharge.



The load automatically reconnects when the battery recovers. A 4-minute delay prevents false LVD disconnects.

- Low Voltage Warning: The red status LED will blink at low battery capacity to warn of a possible LVD.
- Parallel Controllers: ProStar controllers work very well in parallel configurations. No blocking diodes are required. Each controller must have an independent and separate solar subarray and a load that does not exceed the controller's rating.
- Auxiliary Generators: Engine generators and other sources of power may be connected directly to the battery for charging. It is not necessary to disconnect the ProStar from the battery. However, do not use the ProStar to regulate these other sources of power.

**Noise:** The ProStar circuit minimizes switching noise and filters noise output. A properly grounded system will also minimize noise. If noise is present in a telecom or radio load, refer to section 7.5 below.

### 7.3 PROTECTIONS

The ProStar is fully protected against system faults listed below. Recovery is automatic except where noted below. Refer to sections 4.0 and 5.0 for fault indications.

- Solar short circuit and overload – fully automatic recovery
- Load short circuit and overload – after 3 automatic load reconnect attempts (10 seconds between each attempt), the fault must be cleared and the load must be turned off or disconnected for 10 seconds or longer to restore power to the load terminals.

- Reverse polarity – fully protected except per Caution below
- Battery disconnected – the load is protected from voltage spikes
- High temperature – first the solar is disconnected, then the load will be disconnected; auto reconnects
- High battery voltage – first the solar is disconnected, then the load will be disconnected; auto reconnects
- Very low battery voltage – brown-out protection, auto recovery into LVD state
- Battery select error – defaults to gel battery setting, flashes LEDs
- Temperature sensor failure – a remote probe failure defaults to the internal temperature sensor, which defaults to a fixed 25°C if it fails.



**CAUTION:** *The ProStar is protected against all faults EXCEPT a reversed battery connection together with a polarized or short circuited load. CONFIRM that the battery + and – wires are correctly connected before proceeding. Check the wires and the LEDs.*



**PRUDENCE:** *Le ProStar est protégé contre les défauts SAUF un inversé connexion de la batterie avec une charge de court-circuit courte ou polarisée. CONFIRMER que le batterie + et – fils sont connectés correctement avant de continuer. Vérifiez les câbles et les del.*

## 7.4 INSPECTION & MAINTENANCE



**WARNING:** Risk Of Electrical Shock.

**NO POWER OR ACCESSORY TERMINALS ARE ELECTRICALLY ISOLATED FROM DC INPUT, AND MAY BE ENERGIZED WITH HAZARDOUS SOLAR VOLTAGE. UNDER CERTAIN FAULT CONDITIONS, BATTERY COULD BECOME OVER-CHARGED. TEST BETWEEN ALL TERMINALS AND GROUND BEFORE TOUCHING.**



**AVERTISSEMENT:** Risque De Choc Électrique.

**NON ALIMENTATION OU AUX BORNES D'ACCESSOIRES SONT ISOLÉS ÉLECTRIQUEMENT DE L'ENTRÉE DE C.C ET DOIT ÊTRE ALIMENTÉS À UNE TENSION DANGEREUSE SOLAIRE. SOUS CERTAINES CONDITIONS DE DÉFAILLANCE, LA BATTERIE POURRAIT DEVENIR TROP CHARGÉE. TEST ENTRE TOUTES LES BORNES ET LA MASSE AVANT DE TOUCHER.**

The following inspections and maintenance tasks are recommended at least two times per year for best controller performance.

1. Confirm that the correct battery type is selected. Turn the rotary switch to another setting and then back to the setting desired, and count the LED flashes.
2. Confirm that the maximum current of the solar array and load does not exceed the ProStar ratings.
3. Tighten all the terminals. Inspect for loose or broken wire connections.
4. Check that the controller is securely mounted in a clean, protected environment.

5. Check that the air flow and the ventilation holes are not blocked.

6. Inspect for dirt, insects, nests, and corrosion.

7. Check that the controller functions and LED indicators are correct for the system conditions at that time.

## 7.5 TELECOM NOISE JUMPER

Some telecom equipment will produce noise when the ProStar begins PWM regulation. If this occurs, a jumper can be cut to eliminate the noise. Instructions follow:

- First, try to improve the system grounding which often eliminates the noise. The PWM battery charging provides a significant benefit to the battery, and it is worth trying to preserve the PWM charging.
- If the noise continues, disconnect the controller and remove the ProStar assembly from its plastic case.
- Locate a vertical resistor in the upper right hand corner of the board, near the microcontroller. This is identified as "J11" on the board.
- Cut one leg of the resistor and separate the leads.

This will convert the battery charging to a typical "on-off" regulation of the solar energy. The switching is very slow, so the noise will not be noticeable. The equalization and float features of the battery charging algorithm are preserved in the "on-off" mode.

In the future, this can be reversed back to PWM if the cut jumper leg is soldered back together.

## 8.0 BATTERY CHARGING INFORMATION

The ProStar is an advanced, fully automatic solar battery charger. No adjustments are required except to select the battery type at installation (see section 8.2 below).

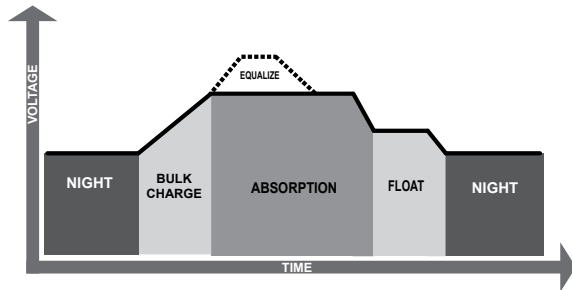

### 8.1 PROSTAR CHARGING METHOD

The ProStar uses 4 stages of charging for rapid, efficient and safe battery charging. These are shown in the diagram above:

1. Recharging with 100% of available solar energy.
2. PWM constant-voltage regulation to prevent heating and excessive battery gassing. Pulse charging to restore full battery capacity.
3. Float: After battery is fully recharged, ProStar reduces to a float or trickle charge. The transition depends on battery history. A load that exceeds available solar output will return ProStar to the PWM mode.
4. Equalize: A boost charge that depends on elapsed time and battery history. Flooded cells receive a vigorous equalization, sealed batteries a smaller boost to

bring uneven cells into balance and extend the battery life. Gel cells are not equalized.

### 8.2 SELECT BATTERY TYPE

The Battery Type rotary switch allows selection of 1 of 3 charging algorithms. These are broadly defined as the following battery types as noted on the lower label:

1. Gel: Some gel and other battery types recommend lower regulation voltages and no equalization. This setting regulates to 14.0V (for a 12V battery).
  2. Sealed: AGM, "maintenance free" and some types of gel batteries. Regulates to 14.15V (12V battery) with 14.35V boost charging.
  3. Flooded: Vented cells that require water to be added. Regulates to 14.4V with 14.9V and 15.1V equalizations (12V battery).
- The above values are 2 times for 24V, and 4 times for 48V. The battery type selection can be changed at any time.

### 8.3 PROSTAR CHARGING FEATURES

Other ProStar capabilities for best battery life follow:

- Night Disconnect: The solar array automatically disconnects at night to prevent reverse current leakage from the battery.
- Battery Sense: Good battery performance requires accurate charging. Voltage drops in the battery power cables can distort the battery charging. The Sense wires eliminate the voltage drops for optimized charging.

- Temperature Compensation: Four control setpoints (25°C reference) are compensated for temperature (PWM regulation, float, equalization, high voltage disconnect). The charging is compensated by  $-5 \text{ mV}/^\circ\text{C}$  /cell ( $-30\text{mV}/^\circ\text{C}$  for a 12V battery). Compensation is limited to minus 30°C.

- Battery Equalization:

	Sealed	Flooded
Calendar – 25 days		
Equalization voltage	14.3	14.9
Cumulative time	1 hour	1 hour
Time starts above (V)	14.3	14.6
Battery History (flooded only)		
Battery voltage falls below (V)	N/A	11.7
Equalize voltage		15.1
Cumulative time		2 hours
Time starts above (V)		14.6
Reset 25-day calendar		yes

**NOTE:** Multiply the preceding battery set-points by two for 24V systems.

## 9.0 TESTING and TROUBLESHOOTING

### 9.1 SELF-DIAGNOSTICS

If your ProStar includes the optional digital meter, refer to section 5.4 for how to perform a self-test of the ProStar. This will test for almost all failure modes of the ProStar and display any faults that are found.

If the self-diagnostic test indicates that no failures were found, it is very likely that the problem is with the solar system or battery.

### 9.2 TECHNICAL SUPPORT

Additional technical information and support can be found at Morningstar's Website:

[www.morningstarcorp.com](http://www.morningstarcorp.com)

### 9.3 TESTING WITH A POWER SUPPLY

The ProStar can be tested with a power supply used in place of either the solar array input or the battery. To avoid damage to the ProStar, observe the following cautions:

- Current limit the power supply to no more than half the ProStar rating.
- Set the power supply to 15 Volts DC or less for 12V systems (30V for 24V systems and 60V for 48V systems).
- Connect only one power supply to the controller.

**Failure to follow these precautions may void the warranty.**

## 9.4 TROUBLESHOOTING

The ProStar is assembled with automated equipment, tested with computers, and is protected from faults. It is usually worthwhile to troubleshoot the entire solar system for faults, since the ProStar will generally not be the cause of a problem. Most problems will be caused by wiring connections, batteries unable to hold a charge, or faulty loads.



**WARNING: RISK OF ELECTRICAL SHOCK.**

*NO POWER OR ACCESSORY TERMINALS ARE ELECTRICALLY ISOLATED FROM DC INPUT, AND MAY BE ENERGIZED WITH HAZARDOUS SOLAR VOLTAGE. UNDER CERTAIN FAULT CONDITIONS, BATTERY COULD BECOME OVER-CHARGED. TEST BETWEEN ALL TERMINALS AND GROUND BEFORE TOUCHING.*



**AVERTISSEMENT: RISQUE DE CHOC ÉLECTRIQUE.**

*NON ALIMENTATION OU AUX BORNES D'ACCESSOIRES SONT ISOLÉS ÉLECTRIQUEMENT DE L'ENTRÉE DE C.C ET DOIT ÊTRE ALIMENTÉS À UNE TENSION DANGEREUSE SOLAIRE. SOUS CERTAINES CONDITIONS DE DÉFAILLANCE, LA BATTERIE POURRAIT DEVENIR TROP CHARGÉE. TEST ENTRE TOUTES LES BORNES ET LA MASSE AVANT DE TOUCHER.*



**WARNING: Shock Hazard**

*A means of disconnecting all power supply poles must be provided. These disconnects must be incorporated in the fixed wiring. Open all power source disconnects before accessing wiring.*



**AVERTISSEMENT: Risque de décharge électrique**

*Un moyen de déconnexion de tous les poteaux d'alimentation doit être fourni. Ceux-ci se déconnecte doit être intégrée dans le câblage fixe. Ouvrir que toutes les source d'énergie se déconnecte avant de accès au câblage.*

1. Troubleshooting must be done by qualified personnel.
2. A battery can cause serious damage if shorted.
3. There are no user serviceable parts, fuses or circuit breakers inside the ProStar.

**NOTE:** If soldering is required, simply solder-through the conformal coating. The coating is acrylic and does not affect soldering.

### 1. BATTERY IS NOT CHARGING

- Check the green CHARGING LED above the Solar input. With sunlight on the solar array, this LED should be on.
- Check that the proper BATTERY TYPE has been selected.
- Check that all wire connections in the system are correct and tight. Check the polarity (+/-) of the connections.

- Measure the solar array open-circuit voltage (disconnect from the controller) and confirm it is normal. If the array voltage is low or zero, repair the fault in the array.
- Confirm that the load is not drawing more energy than the solar array can provide.
- If the BATTERY SENSE terminals are not used, there may be excessive voltage drops between the ProStar and the battery. This is a common cause of undercharging batteries. See section 6.2 to connect the Battery Sense.
- Check the condition of the battery. Determine if the battery voltage falls at night with no load. If the battery is unable to maintain its voltage, it may be failing
- Measure the solar input voltage (during daytime) and battery voltage at the ProStar terminals. If the voltages at the terminals are the same (within about 0.5 Volts), the solar array is charging the battery. If the solar voltage is close to open-circuit (about 20V), and the battery voltage is low, the controller is not charging the battery and may be defective. Make sure the ProStar is not in regulation (PWM) for this test (see section 4.0).

**NOTE:** If the battery is not being fully recharged, measure the voltage at the battery terminals on the ProStar, and then at the terminals on the battery. This should be done at mid-day with full charging from the solar array (and not in PWM regulation). If the ProStar terminals are 1 volt higher than the battery terminals, for example, this voltage drop will cause the battery to regulate 1 volt below its desired regulation (PWM) voltage, and it will take longer to recharge. In this case, the SENSE terminals should be connected to the battery for accurate charging.

## 2. BATTERY VOLTAGE IS TOO HIGH

- First check the operating conditions to account for temperature compensation (a 15°C / 59°F temperature will increase PWM regulation by 0.3V for a 12V battery) and automatic equalizations.
- Check that the proper battery type has been selected.
- Disconnect the solar array, and remove the battery wire from the ProStar battery positive (+) terminal. Wait a few seconds and reconnect the battery positive terminal (leaving the solar array disconnected). After start-up, the green CHARGING LED should not be on. Measure the voltage at the SOLAR terminals (with the array still disconnected). If battery voltage is measured at the SOLAR terminals and the green LED is on, the controller may be defective.

**NOTE:** If your ProStar is a positive ground version, references above to Battery (+) terminals should be Battery (-) negative terminals.

## 3. LOAD IS NOT OPERATING PROPERLY

- Check that the load is connected and turned on. Confirm that no fuses or circuit breakers in the system are tripped (there are no fuses or circuit breakers inside the ProStar).
- Check all connections to the load, and battery connections. Make sure voltage drops in the system are not too high (a voltage drop to the load will reduce the voltage at the load).

- Check the LED indications on the ProStar. If the red status LED is on, the load has been disconnected due to low battery voltage (LVD). This is a normal protection function of the ProStar, and the load will be automatically reconnected when the battery is charged by the solar array.

- If the LEDs are blinking, the load may have been disconnected for protection from one of the following faults:

1. Short circuit or overload (R/G–Y sequencing)

**NOTE:** After 3 automatic retries, the fault must be cleared and the load must be switched off or disconnected for 10 seconds or longer to restore power to the load terminals.

2. High temperature (R–Y sequencing)

3. High voltage (R–G sequencing)

- Measure the voltage at the BATTERY terminals. If above LVD and no faults are present, the load should have power. Then measure the voltage at the LOAD terminals, and if there is no voltage present the controller may be defective.

**NOTE:** For more technical and testing information, visit Morningstar's website:

[www.morningstarcorp.com](http://www.morningstarcorp.com)

## 10.0 TECHNICAL SPECIFICATIONS

**NOTE:** If not stated, values are for 12V versions. Multiply by two for 24V values.

Accuracy:

12V 40 mV

24V 60 mV

Minimum voltage to operate:

12/24V 8 V

Self-consumption:

12/24V 22 / 25 mA

LVD current coefficient:

12 / 24 V –20 mV/amp load

High temp shutdown:

70°C disconnect solar

80°C disconnect load

60°C reconnect load

50°C reconnect solar

Voltage drops (max.):

solar / battery 0.2 V

battery / load 0.12 V

Operating life: 15 years

Transient surge protect pulse power rating 1500 watts response: < 5 nanosec

**Meter Display:**

Type

LCD

Temperature rating

–30 to +85°C

Voltage accuracy

0.5%

Current accuracy

2.0%

Self-consumption

1 mA

### Battery Status LEDs:

	V Falling	V Rising	
G to Y	12.1	13.1	Y to G
Y to Blink R	11.7	12.6	R to Y
Blink R to R	11.4	12.6	Blink R to Y

### Battery Set-points:

	Gel	Sealed	Flooded
LVD	11.4	11.4	11.4
LVD reconnect	12.6	12.6	12.6
PWM regulation	14.0	14.15	14.4
Float	13.7	13.7	13.7
Equalization	N/A	14.35	14.9 / 15.1
HVD (solar)	15.2	15.2	15.2
HVD (load)	15.3	15.3	15.3

### Battery Charging:

Charge algorithm	PWM, constant voltage
Temp comp. coefficient	-5mV/°C/cell (25°C ref)
Temp comp. range	-30°C to +80°C
Temp comp. setpoints	PWM, float, equalize, HVD
Equalization	See section 8.3

### Mechanical:

Dimensions	
Inches:	6.01 x 4.14 x 2.17
Millimeters:	153 x 105 x 55
Weight:	12 oz (0.34 kg)
Wire terminals:	Euro-style
Solid	#6 AWG / 16 mm <sup>2</sup>
Multi-strand	#6 AWG / 16 mm <sup>2</sup>
Fine strand	#8 AWG / 10 mm <sup>2</sup>
Terminal diameter	0.210 in / 5.4 mm
Torque terminals	up to 35 in-lb
<b>Environmental:</b>	
Ambient temperature	-40 to +60°C
Storage temperature	-55 to +85°C
Humidity	100% (NC)



## 11.0 CERTIFICATIONS



- IEC 62109
- Complies with the US National Electric Code
- Complies with the Canadian Electrical Code
- FCC Class B compliant

ENs Directives:

- Complies with ENs and LVD standards for CE marking
- Immunity: EN61000-6-2:1999
- Emissions: EN55022:1994 with A1 and A3 Class B1

ProStar™, ProStar MPPT™, MeterBus™ are trademarks of Morningstar Corporation

MODBUS™ and MODBUS TCP/IP™ are trademarks of Modbus IDA. [www.modbus-ida.org](http://www.modbus-ida.org)

© 2017 Morningstar Corporation. All rights reserved.